

force[⚡] smart door automation

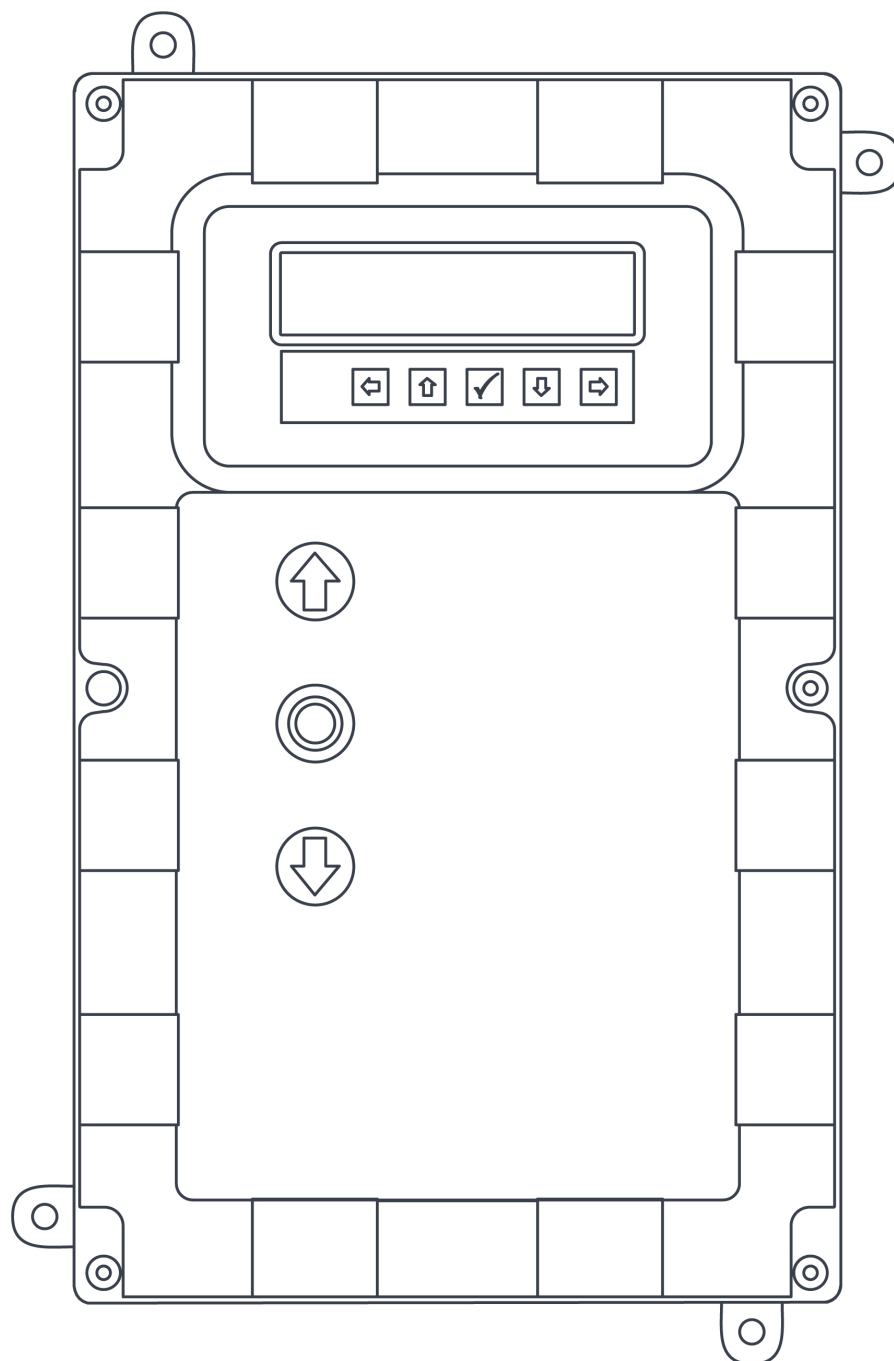

Copyright and Disclaimer Notice

Although the contents of this publication have been compiled with the greatest possible care, FlexiForce cannot accept liability for any damage that might arise from errors or omissions in this publication. We also reserve the right to make appropriate technical modifications/replacements without prior notice.

No rights can be derived from the contents of this document.

Colour guides: Colour differences may occur due to different printing and publication methods.

Copyright FlexiForce Group 2015.

All rights reserved

Contents

Copyright and Disclaimer Notice	2
Contents	3
1. About this Manual	4
1.1 Safety Symbols Used in this Manual	4
2. force70/100/140 operator	5
2.1 Safety instructions	5
2.2 Preparation	5
2.3 Electrical preparations	5
2.4 Assembling the drive unit	6
2.5 Drawings / dimensions	7
3. forceIQ control unit	8
3.1 Installation	8
3.1.1 ForceIQ 230V single phase preparation	9
3.1.2 ForceIQ 400V preparation	9
3.2 Technical data	10
3.3 forceIQ menu overview	11
3.3.1 Access the Menu	12
3.4 Programming	12
3.4.1 Changing the language	13
3.4.2 Motor setup	14
3.4.3 Adjusting the end position	16
3.4.4 Safety device	18
3.4.5 Operating mode	20
3.4.6 Code entry	20
3.4.7 Special setup	21
3.4.8 Service	24
4. Optional plug on	26
4.1 Module Bracket	26
4.2 forceLD: Loop Detector	27
4.3 forceRX4: Radio receiver	28
4.4 forceTL: Traffic Lights	28
4.5 force Photocells	29
4.6 forceOCE	30
4.7 forcePSE	30
4.8 force668LM Electronic lock	32
5. Trouble shooting	32
6. Appendix	34
6.1 Additional function-terminals	
6.2 Wiring diagrams	
6.3 Declaration of incorporation	

About this Manual



All users and owners of the Industrial door must read, understand and obey the information and instructions in this manual. Failure to do so may result in damage to, or failure of the equipment, and possible injury to persons.

This manual contains functional descriptions and installation information for an Industrial door. When information or instructions are applicable to all the methods of operation or models, there are no operator types or model numbers in the title. When information or instructions are applicable to specific methods of operation or models, the applicable operation type or model numbers appear in the title.

1.1. Safety Symbols Used in this Manual

The following safety symbols are used in this manual:



Indicates a general warning



Indicates an electrical hazard



Specific useful information concerning the installation.

2. Force70XQ/100XQ/100XC/140XQ operator

2.1. Safety instructions

- Follow all instructions since incorrect installation can lead to severe injury.
- Check that the temperature range marked on the operator is suitable for the location.
- Check that the door is moving smooth and correct before assembling the operator.
- Check that the door is in good mechanical condition and is correctly balanced.
- After installation, ensure that the mechanism is properly adjusted and that the protection system and any manual release function correctly.
- Ensure that entrapment between the driven part and the surrounding fixed parts due to the opening movement of the driven part is avoided.
- External push button units are to be located within direct sight of the door but away from moving parts. Unless it is key operated, it is to be installed at a minimum height of 1,5 m and not accessible to the public.

2.2. Preparation

Before you start make sure that the following preparations are done:

- Approval/communication with customer completed.
- Materials on site are complete.
- All measurements are correct.

2.3. Electrical preparations

The manually operated door needs no electrical supply. For an electrically operated door, the following environment criteria and electrical supplies are required for the operator to function properly:

	force100XQ/XC	force140XQ	force70XQ
Voltage supply: +/- 10%	400V AC 3-phase 50Hz, 10A	400V AC 3-phase 50Hz, 10A	230V AC 1-phase 50Hz, 10A
Power:	0,37 kW	0,55 kW	0,50 kW
Degree of protection:	IP54	IP54	IP54
Weight:	13 kg	13 kg	11,5 kg
Allowed door weight, max.:	400 kg	650 kg	350 kg
Temperature working range:	-15 °C to +50 °C	-15 °C to +50 °C	-10 °C to +40 °C
Operating factor, Duty cycle:	40% S3 10 min. Intermittent	40% S3 10 min. intermittent	25% S3 10 min. intermittent
Dimensions force..XQ (hxwx):	375 x 260 x 110 mm	375 x 260 x 110 mm	380 x 110 x 250 mm
Dimensions force..XC (hxwx):	425 x 110 x 260 mm		

2.4. Assembling the drive unit



The door must be correctly installed, balanced and be in closed position before the assembly of the operator. For the operator a mounting attachment of >500N is required.

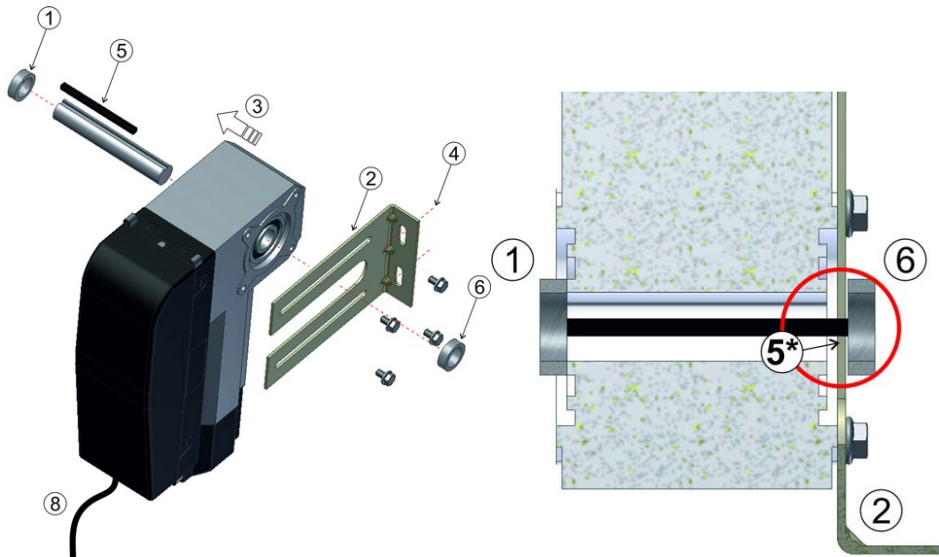

1. Attach the first stop ring to the shaft.
2. Attach the wall bracket with 4 screws and washers to the motor.
3. Push the operator completely against the stop ring.
4. Mount the wall bracket to the wall with two suitable screws and washers.
 - Per mounting attachment >500N is required.
5. Disengage the drive unit from the door shaft by moving the handle clockwise until it stops, then aim for the keyways at the door shaft and the operator. *The wedge should protrude a few mm from the wall bracket.
6. Attach the second stop ring. A gap of a few mm should remain between the stop ring and the wall bracket.
7. Tighten all screws.
8. Route the cable down to the control unit.

2.5 Drawings / dimensions

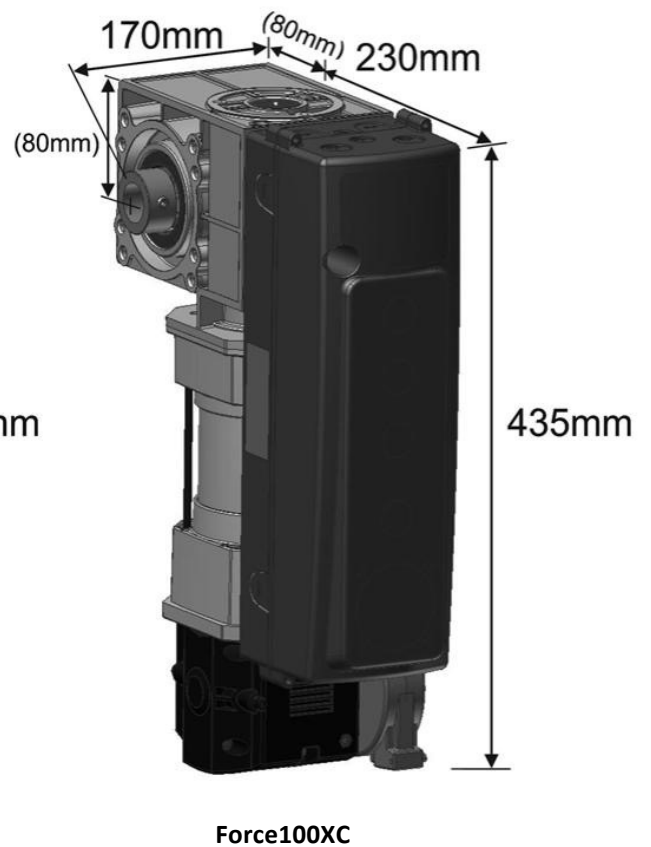
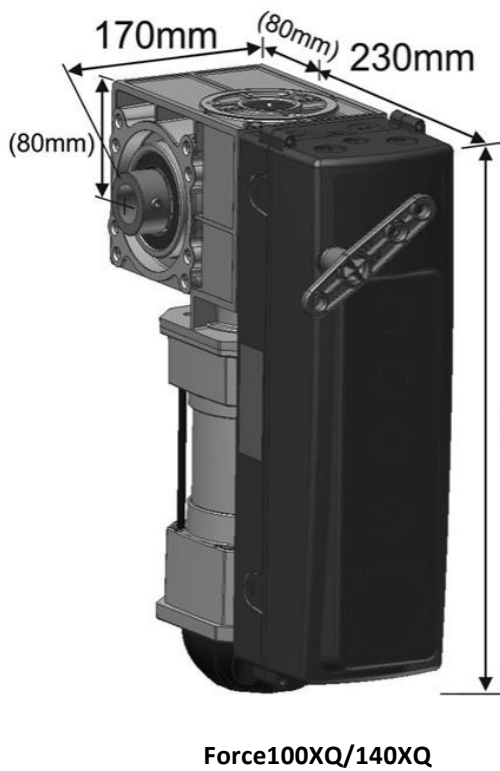
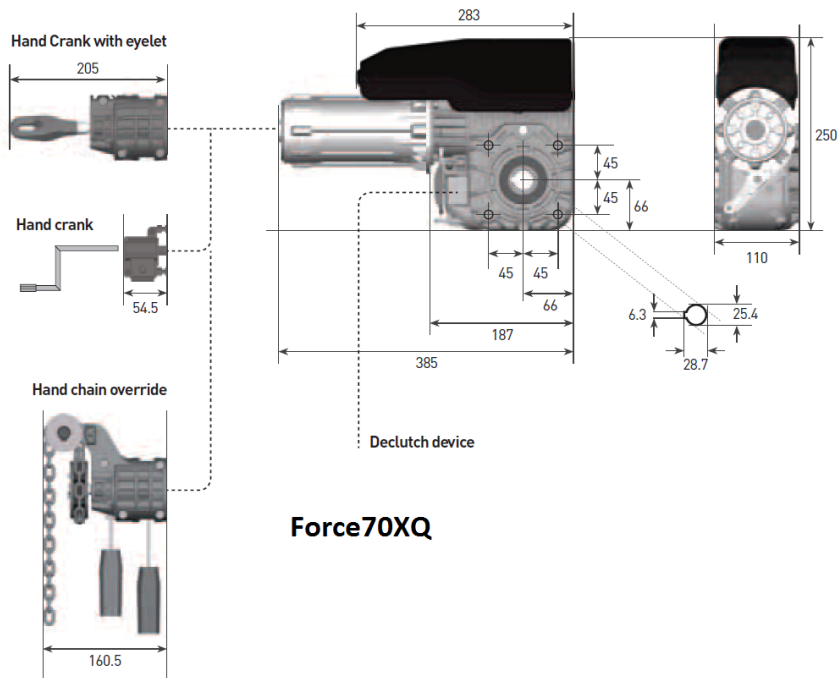

3. forceIQ control unit

3.1 Installation

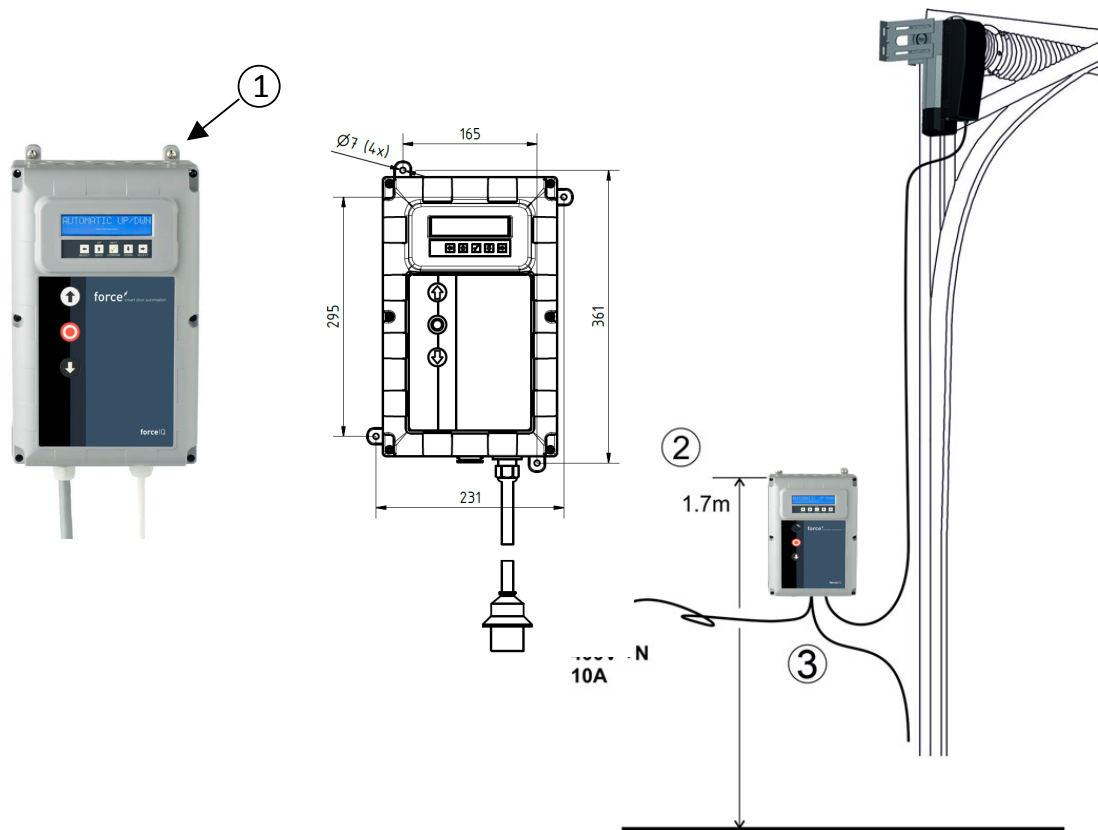

1. At the rear of the control unit you have to assemble 4 enclosure brackets before mounting it to the wall. Use the four small 5x12 screws.
2. Mount the Control unit approx. 1.7m above the floor (measured from the upper side of the box).
3. Connect the cables from the door leaf and the drive unit, according in the instructions by the wiring diagram. The control unit is now assembled and ready to be functionally installed. See paragraph "Programming" concerning the programming procedure.
4. Check the control board of the ForceIQ if it is prepared for 230V or 400V operator. See next page for the right preparation.

3.1.1 ForcelQ 230V single phase preparation

Connect as below when you use the ForcelQ with a 230V single phase motor.

Make sure Fuse F4 is 100mA medium and that KL13-1 and KL13-2 are connected together.

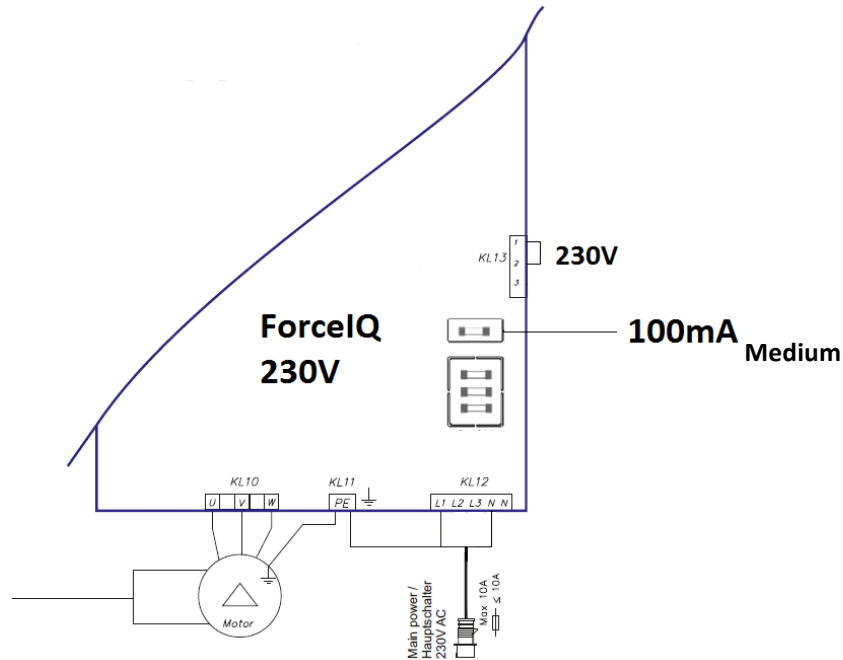

3.1.2 ForcelQ 400V preparation

Connect as below when you use the ForcelQ with a 400V motor.

Make sure Fuse F4 is 80mA slow and that KL13-2 and KL13-3 are connected together.

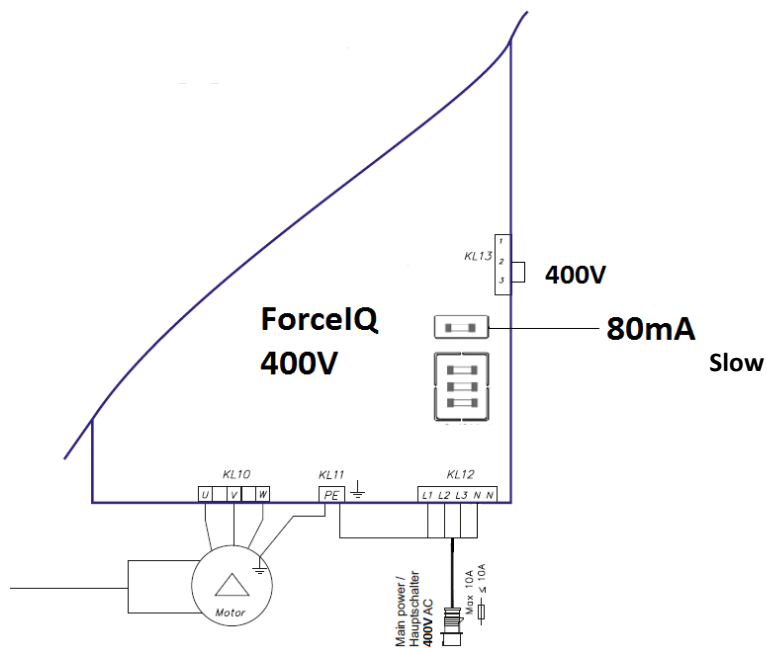

3.2 Technical data

Dimensions (approx.):	345x215x135mm
Main supply voltage L1, L2, L3, N, PE:	forceIQ- 400V, 50HZ / forceIQ-230 230V, 50Hz.
Fuse protection	10A K - characteristic
Voltage	24V DC, max. 320mA
Access input	24V DC, All inputs must be absolutely potential free connected. Minimum duration of input signal control command >100ms.
Safety circuit / Emergency stop	Connect all inputs absolutely potential free; at interruption in the security circuit, it is not longer possible of electrical operation of the motor, even in hold-to-run mode.
Input safety rail	For electrical safety strips with 8.2k Ω , load resistor and for dynamic optical systems.
Relay output	If used as power switching contacts, it cannot serve more small electric currents.
Temperature range:	-15°C - +50°C
Protection	IP 54 (in housing)
Weight	Ca. 2.2 kg

3.3. forceIQ menu overview

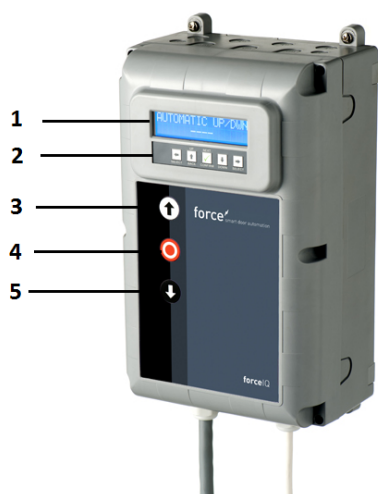

ForceIQ

1. Display
 2. Keypad
 3. Push-button "UP" (door opens)
 4. Push-button "STOP" (door stays in position)
 5. Push button "DOWN" (door closes)
- ← Menu selection (left)
- Menu selection (right)
- ✓ Confirm
- ↑ Change number values & end position setting
- 1 push, return to the menu selection
 - 2 push, return to the operating mode
- ↓ Change number values & end position setting.

3.3.1. Access the Menu

1. Press and hold the push-button STOP for 6 seconds to activate the keypad and to access the menu.
2. Enter the access code*. You now have access to the menu. The display will show plain text commands, messages, and error messages. The keypad is used to navigate through the menu, to confirm and to save. * Standard access code is "00000".

3.4. Programming



Before programming the Control Unit: Make sure that you connect all the devices like in the Basic Wiring Diagram.

- Place the door 1.5m above the floor.
- Ensure that the floor is clean and free from cables etc.
- Programming can only be carried out using the set of buttons in the control box, not an external push button box or radio control. For doors with small drums and without safety features, there may be a risk of the cable unwinding. Check therefore that the cable is placed correctly on the drum.

In the main menu it is possible to switch between the following menu items by pressing the ◀ or ▶ button.

1) Language	13
2) Motor setup	14
3) Adjust end position	16
4) Safety device	18
5) Operating mode	20
6) Code entry	20
7) Special setup	21
8) Service	24

Press the ✓ button to enter the selected menu.

3.4.1. Changing the language

- use the ◀ or ▶ buttons to select your desired language.
 - Dutch
 - German
 - English
 - Italian
 - French
 - Spanish
 - Polish
 - Swedish
 - Hungarian
 - Romanian
- Press ✓ to confirm and save.
- Press ⬆ to return to the main menu.
- Press ⬆ once more to enter the maneuvering mode.

3.4.2 Motor setup

Use the ← or → buttons to select one of the following menu items:



- 1) Motor direction
- 2) Encoder direction
- 3) Motor controller
- 4) Limit sw. type
- 5) Lift force detection
- 6) Inv. profile up ⓘ (Only for inverter operator)
- 7) Inv. profile down ⓘ (Only for inverter operator)
- 8) Fu profile boost ⓘ (Only for inverter operator)

- 1) **Motor direction:** Use the ← or → button to change the motor direction to "left" or "right". Press ✓ twice to confirm.
- 2) **Encoder direction:** Use the ← or → buttons to change the encoder direction to "Clockwise" or "Anti-clockwise". Press ✓ twice to confirm.
- 3) **Motor controller:** Use the ← or → buttons to choose between "Contactor relay" and "Inverter rue". Press ✓ twice to confirm. Use "Contactor relay" for Force operators. Choose "Inverter rue" for frequency converters
- 4) **Limit sw. type:** Use the ← or → buttons to choose between several limit switch types. Press ✓ twice to confirm. For the force70/100/140 control unit choose "Kostal".. If you are not sure what kind of limit switch you have to use, contact your operator supplier.
- 5) **Lift force detection:** As default the lift force detection is disabled. To prevent the door from being able to lift a person, the lift force detection shall be activated and adjusted to make the door weaker.



To set the lift force detection, navigate to the "Lift force det." menu item and press ✓ to select the menu item.

- Navigate to "Lift force det. Test drive" Press ✓. Hold-to-run the door down to closed position. Then run up to fully open position in hold-to-run mode uninterrupted, to record the normal door run (plot).
- Navigate to "Lift force det. up". Press ✓ and the display shows "up disabled". With the UP and DOWN button one can enable and increase the lift force detection from 0,% (disabled) to 20% (strongest). Recommended is to start at 5%. Press ✓ to confirm selected value.
- Press ↑ to return to the main menu. Press once more to enter the manoeuvring mode.
- Now you can verify if your setting is acceptable in the upwards direction. If the door is too strong or too weak repeat step 2 and 3, then verify the current value.
NOTE! The door runs a while to detect the weight.



6) Inv. profile up  *Only for inverter operator*

Use the    buttons to adjust the following parameters:

- Max speed (Hz) *the maximum speed after acceleration*
- Min speed (Hz) *the speed after deceleration*
- Start ramp (ms) *acceleration time*
- Slowdown slope (ms) *deceleration time*
- Stop ramp (Incr.) *value before the end position were the slope has to start*



Press  to return to the main menu. Press  once more to return to the manoeuvring mode

7) Inv. profile down  *Only for inverter operator*

Use the    buttons to adjust the following parameters:

- Max speed (Hz) *the maximum speed after acceleration*
- Slow speed (Hz) *the speed after deceleration*
- Medium speed (Hz) *the speed after reach position medium speed (see point 8 page 14)*
- Start ramp (ms) *acceleration time*
- Slowdown slope (ms) *deceleration time*
- Stop ramp (Incr.) *value before the end position were the slope has to start*

8) Fu profile boost  *Only for inverter operator*

Use the    buttons to adjust the following parameters:

- Rated frequency (Hz) *nominal frequency of the motor*
- Boost (%) *to increase the voltage by low frequency*

3.4.3. Adjusting the end position





Warning:

Risk of material damage: The door could be moved beyond the upper and lower end position manually during installation (in hold to run mode). This may result in damage to the door.
Observe the door during setting the end positions permanently.



Before adjusting the end position: Place the door in the middle position. Check if the door goes up when the  button is pushed. If the door does not go up then change the direction of the motor. (See page 12 "Motor direction")

Use the  or  buttons to select one of the following menu items:

- 1) Top
- 2) Bottom
- 3) Brake offset
- 4) Fine pitch up
- 5) Fine pitch down
- 6) Pre end position
- 7) Safety limit
- 8) Pos med speed

Press  to enter the selected menu item.

- 1) **Top:** Run the door in the desired position using  or . press  to confirm end position.











Check if the counter counts up when the door goes up. If the counter doesn't count up, change the direction of the encoder. (See paragraph "Motor setup").

Use the  and  button to select the bottom adjustment.

- 2) **Bottom:** Run the door in the desired position using  or . Press  to confirm the end position.



Function control: Test the safety edge setting by using a 30x50mm gauge block. Run down the door to the 50mm side of the block, and the door must reverse up again. Run down to the 30mm side of the block, and the door must stop. You can adjust the height of the limit with point 6 "pre-end position"

- 3) **Brake offset:** Use the    buttons to adjust this position. *Can be used for heavy and light doors. See for more info next page.*
- 4) **Fine pitch up:** If needed, use the    buttons to define the exact top end position of the door
- 5) **Fine pitch down:** If needed, use the    buttons to define the exact bottom end position of the door.

- 6) **Pre end position:** Use the buttons to adjust this position. *This is the point where the safety edge changes from reverse to stop when triggered.*
- 7) **Safety limit:** Use the buttons to adjust this position. *here you can adjust the safety limit switch. So when the door is running through the end position, the safety limit switch will automatically stop the operator. Default is 100*
- 8) **Position medium speed** (Only for inverter operator): Use the buttons to adjust this position. *The position medium speed is the position at which the door will switch from fast speed to medium speed when the door is moving down.*

Please let the door run four times up and down.

If the end positions are correct, Press to return to the main menu . Press once more to return to the maneuvering mode.



After adjusting the end positions, check the quick release or the safety chain if they work probably. Check this when the door is in close position. When it is hard to move the chain or quick release, then check if there is tension on the cables and springs and if the door is not pushing too tight on the floor.









Brake offset

The brake offset parameter is used for automatic mode with encoder. It is the initial value where the automatic brake point adjustment function switching on the brake and switching of the motor. This function detects when the door does not stop on the defined endpoint and modifies the brake offset point. For a heavy or fast door, the default value can be too low. In this case the door can run over the end positions. For small or slow doors, the default value can be too high. In this case the door will run too short in the first 2-3 runs in automatic mode after setting the end positions.

If the end positions are changed, this function needs to run a couple of times in automatic mode, in order to get a good measurement on where the door stops again.

There is no need to do the fine tuning of end positions when using an encoder (provided that the end position is in the correct place). Instead just run the door a few times in automatic mode and let the controller manage the adjustment.

3.4.4. Safety Device

	<p>Depending of what kind of safety device is used, you can choose between following actions when safety device is triggered.</p> <ul style="list-style-type: none"> • Down full reverse : door returns to top end position, by activation while door is closing. • Down part reverse: door returns a couple of cm, by activation while door is closing. • Down stop: door stops, by activation while door closing. • Pull-in protect: door stops by activation while door go's up. • Down full /sw off: to adjust the position to deactivated the photocell that is active in downward direction. Use the    buttons to adjust the position to deactivated the photocell. • Pull-in masked: to adjust the position to deactivated the photocell that is active in upward direction. Use the    buttons to adjust the position to deactivated the photocell.
---	--

Use the  or  buttons to select one of the following menu items:

- 1) 4-wire photocell KL5
- 2) 2-wire photo KL6
- 3) OSE 1 setup KL3
- 4) OSE 2 setup KL4
- 5) Safety 1 KL2 1-2
- 6) Safety 2 KL2 3-4
- 7) Reverse Delay
- 8) Fine pitch disable photoc.

Press  to enter the selected menu item.

- 1) **4-wire photocell KL5**: Use the  or  buttons to select one of the following menu items:

- **Disabled**: When KL5 is not in use
- **Light curtain**: When a light curtain is connected
- **Untested**: When a photocell is connected without a self test
- **Tested**: When a photocell is connected with a self test (switch on 24V test voltage for test)
- **Tested inv.** When a photocell is connected with a self test (switch off 24V test voltage for test)

- 2) **2-wire photo KL6**: *Not in use*

- 3) **OSE 1 setup KL3**: Use the  or  buttons to select one of the following menu items:

- **Disabled**: When KL3 is not in use
- **OSE**: When safety device that works with OSE signal is connected e.g. opto sensors
- **3-w photoc.:** When a 3 wired photocell is connected

4) **OSE 2 setup KL4:** Use the ← or → buttons to select one of the following menu items:

- **Disabled:** When KL4 is not in use
- **OSE:** When safety device that works with OSE signal is connected e.g. opto sensors
- **Wireless OSE:** When a wireless OSE safety device is connected
- **4-w photoc.:** When 4 wired photocell is connected e.g. pre-running photocel

5) **Safety 1 KL2 1-2:** Use the ← or → buttons to select one of the following menu items:

- **Disabled:** When KL2 1-2 is not in use
- **8k2:** when a safety edge is connected that deactivated 8.2 kΩ
- **Airwave switch:** when airwave switch with 8.2 kΩ is connected. The control unit need a test signal (deactivated 8.2 kΩ) from the airwave switch every time the end position is reached
- **Passdoor:** when a safety edge is connected that deactivated 8.2 kΩ. (special passdoor mention)
- **Tested passdoor:** radio safety edge for passdoor

6) **Safety 1 KL2 3-4:** Use the ← or → buttons to select one of the following menu items:

- **Disabled:** When KL2 3-4 is not in use
- **8k2:** when a safety edge is connected that deactivated 8.2 kΩ
- **Airwave switch:** when airwave switch with 8.2 kΩ is connected. The control unit need a test signal (deactivated 8.2 kΩ) from the airwave switch every time the end position is reached
- **Passdoor:** when a safety edge is connected that deactivated 8.2 kΩ. (special passdoor mention)
- **Tested passdoor:** radio safety edge for passdoor

7) **Reverse Delay:** Use the ↑↓✓ buttons to adjust this value

set the reverse time between 20 and 600 mSec. Selecting a smaller value gives you a faster reversing, but also a more distinct running of the door, a bigger value gives a smooth, but longer reversing sequence. The default value is 80mSec.

**Warning:**

Changing the Reverse delay value will influence the peak force value of the door

8) **Fine pitch disable photoc.:** Use the ↑↓✓ buttons to adjust this value *Here you can fine pitch the "Down full /sw off " position from where the photocells have to be disabled. (e.g. where the photocells are mounted in the doorway).*

3.4.5. Operating mode

Use the ← → ✓ buttons to select one of the following menu items:

- **Automatic UP/DOWN:** the door opens and closes in automatic mode. *(only if safety edges are ok and activated)*
- **Deadman UP/Down:** the door opens and closes in hold to run mode
- **Automatic UP/Deadman DOWN:** the door opens automatically and closes in hold to run mode



If Automatic UP/DOWN is not in the menu, then there is something wrong with the safety devices or the connected safety devices is not activated in the menu.



Photocells are not safe enough according safety standard, so you won't find automatic UP/DOWN in the menu. Connect one more safety edge for automatic UP/DOWN.

Press ✓ to confirm and save the desired operating mode.

Press ↑ to return to the main menu.

Press ↑ once more to return to the manoeuvring mode

3.4.6. Code entry

Use the ←/ →/ ↑/ ↓ to fill in the new access code.

Press ✓ on the last digit to complete.

Press ✓ to confirm and save the new code.

Press ↑ to return to the main menu.

Press ↑ to return to the maneuvering mode



The factory code is "00000"

3.4.7. Special setup

Use the buttons to select one of the following menu items:

- 1) Auto close
- 2) Auto open
- 3) Partial open
- 4) Relays
- 5) Traffic light
- 6) CDM6
- 7) Door control mode
- 8) External buttons

1) Auto close: *This will automatically close the door after the set delay.*

Use the buttons to select one of the following menu items:

To set auto close :

- Enabled
- Close delay (use to set time, unlimited means the timer is on but isn't counting)
- Trig. Auto close disabled
- Max emergn rev. (use to set max. number of reverse after safety edge is triggered, after that number "auto close" stops)
- to confirm to confirm and safe
- Press to return to the main menu.
- Press once more to return to the maneuvering mode.

To set auto close after trigger:

- Enabled
- Close delay (use to set on unlimited)
- Trig. Auto close Enabled
- Clearing time (use to set time that the door close after trigger)
- Choose kind of trigger
- Max emergn rev. (use to set max. number of reverse after safety edge is triggered, after that number "auto close" stops)
- to confirm and save
- Press to return to the main menu.
- Press once more to return to the maneuvering mode.







Only photocell 1 can work as a trigger for automatic closing

2) **auto open:** This will open the door automatically after the same delay as "auto close"

**Warning:**

"Auto open" is a test function. Only use for testing!



3: **Partial open:** If you push 2x the up button the door will stop at this point

- Use  or  to adjust to the desired position.
- Press  twice to confirm and save the desired position.
- Press  to return to the main menu.
- Press  once more to return to the maneuvering mode.



2x  = reduced opening. Push 1 x  by reduced opening and the door will fully open
(Not possible with remote control button)

4 Relays:

Use the    buttons to select the "Relays" you want to adjust (relay R1, R2, R3).
In the "Relay type" menu item you can select and adjust the following parameters:

- **Inactive:** to deactivate relay
- **End position:** for contact (permanent or blink) on end position top, bottom or both.
- **Movement:** for contact (permanent or blink) while the door is moving up, down or both. With pre-run option.
- **Electrical lock:** optional for electrical lock (see page 32)
- **Brake:** to set release delay in ms
- **Radio:** not in use
- **Ready for work**.** to select one or more safety edges to switch the relay (see table below)
- **Auto close:** to set time the warning sign has to go on before the door is closing

Press  to confirm and save.

Press  to return to the main menu.

Press  once more to return to maneuvering mode.

** Ready for work:

Trigger	Number code
Optical safety edge 1 (OSE 1 / KL3)	1
Optical safety edge 2(OSE 2 / KL4) or pre-running photocell	2
Safety edge 1 (KL2 1/2)	4
Safety edge 2 (KL2 3/4)	8
4-wire photocell (KL5)	16
2-wire photocell (KL6)	32
Emergency stop (KL7)	64
Safety chain motor (KL8)	128
Passdoor (KL2)	256
Sum of all trigger	511

Example: if you want to switch the relay when OSE 1 is triggered, fill in 1 by ready to work.
If you want to switch the relay when OSE 1 (1) or KL5 (16) is triggered fill in 17. (1 + 16)

5) Traffic light:

This function is used when the door opening is not wide enough for two vehicles to pass at the same time and the traffic must be regulated: who may pass through the door first. Three relays are intended for the red and green lights, on the inside and the outside of the door. The 4th relay can be used for special applications, e.g. garage light, exhaust ventilation, stair light impulse.



Traffic light setting can be set only in combination with optional traffic light module

Use the buttons to choose between:

- Warning light: *lights on both side have the same color.*
- Two way traffic: *light on both side have different color, depending on priority.*

After that use the buttons to set the following options:

- **Lead time open:** A warning in advance can be produced just before the door opens. This will occur by flashing of the red lights. The time is adjustable between 0 and 255 seconds.
- **Opening time.** With the opening time function the time is specified. You can configure how long the door remains in "fully open position" until a suitable pulse to the control is received. The time is adjustable between 0 and 999 seconds.
- **Lead time close.** A warning in advance can be produced just before the door closes. This will occur by flashing of the red lights. The time is adjustable 0-255 sec and starts with the end of the clearing time.
- **Clearing time.** The clearing time offers the possibility to lock the door area for the passage. This may be necessary for longer ways (e.g. ramp in front of the door). This allows vehicles to exit the area before a new vehicle enters. The time starts when the opening time has elapsed. The time is adjustable between 0 and 255 seconds.

If the door reverses due to a safety edge (OSE, photocell etc.) activation, the red light will be set on both sides at the fully open position.

If the stop button is pressed, the two way traffic mode is aborted until the door is closed. The light state can be permanent green/red or red/red in open position depending on when the stop button is pressed. Between the end positions, the light will continue to flash if the stop button is pressed.

The table shows which side that will have the green light depending on what was triggering the opening. The opposite side has red light.

Opening command	Inside green light	Outside green light
Contact unit button	X	
External up button (KL20-1)		X
External one button (KL20-7)	X	
Radio up button (KL1-4)		X
Radio one button (KL1-3)	X	
Induction loop 1 (KL23-5)	X	
Induction loop 2 (KL23-4)		X



Press  to confirm and save.



Press  to return to the "special setup" menu

Press  to return to the main menu.



Press  once more to return to maneuvering mode.

6) CDM6 : choose enabled if you have a Crawford CDM6 operator connected.

7) Door control mode: use    buttons to select "Sectional door" or "High speed door".

- Press  to return to the main menu.
- Press  once more to return to the main menu.

8) External buttons: Use the    buttons to choose between

- **Not active:** external push buttons are disconnected if "hold to run" mode occurs in the control box.
- **Active:** the external push buttons can also be used in "hold to run" mode when "hold to run" mode occurs.
- Press  to return to the main menu.
- Press  once more to return to the main menu.

3.4.8. Service

Use the    buttons to select one of the following menu items:

- 1) Cycles
- 2) Software version
- 3) CFG XML export
- 4) Set time
- 5) Maintenance complete
- 6) Maintenance intervals
- 7) Reset errors
- 8) Event history
- 9) Clear event history
- 10) CFG soft reset
- 11) Factory reset

- 1) **Cycles:** To view the number of door cycles
- 2) **Software version:** To view the current software version,
- 3) **CFG XML export:** To export the config XML, (for internal use only)
- 4) **Set time:** Use ◀ / ▶ and ⬆ / ⬇ buttons to change the current date and time.
- 5) **Maintenance complete:** Select when maintenance is complete. The service intervals are now restored to its pre-settings.
- 6) **Maintenance intervals:** To adjust the number of door cycles or the number or days to indicate when service is needed navigate to the "Maintenance intervals" menu item.
 - **Limit door cycles:** To adjust the number of door cycles (between 11 and 999.999 cycles. Use the ⬆ / ⬇ button to adjust the number of door cycles. The default setting is 25.000 cycles.
 - **Limit days:** To adjust the number of days (between 11 and 999.999 days). Use the ⬆ / ⬇ button to adjust the number of days. The default setting is 365 days.

The display will show "Maintenance interval reached" when the number of days or cycles is reached.

- 7) **Reset errors:** To reset the errors shown.
- 8) **Event history:** To view the event history, use the ◀ / ▶ button to navigate through the history.
- 9) **Clear event history:** To clear the event history
- 10) **CFG soft reset:** for internal use only
- 11) **Factory reset:** To reset the control unit back to the factory settings.
 - Press ⬆ to return to the main menu.
 - Press ⬆ once more to return to the main menu.

4. Optional plug-on modules



The forceIQ control unit can also be programmed to handle multiple optional functions. When external equipments are needed to connect to the control unit, please read the enclosed documentation.

The ForceIQ enables various plug on modules to be directly installed.

These will be pushed in the designated plug-in position and connected with the enclosed adapter cable to the mainboard of the forceIQ.

4.1 Module Bracket

Module Bracket is installed directly above the main board in the control housing.

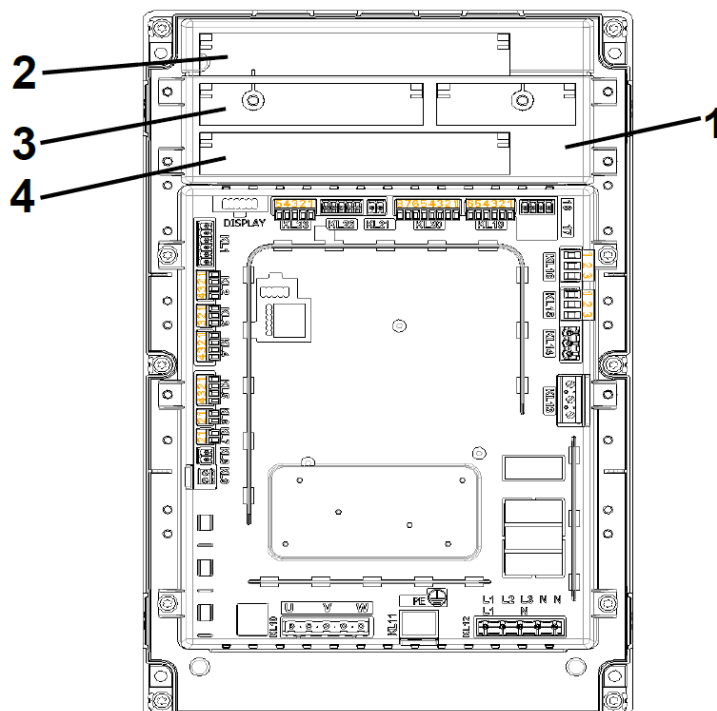

- 1. Module bracket
- 2. Traffic light module
- 3. Loop detector module
- 4. Radio receiver module

4.2. forceLD: loop detector

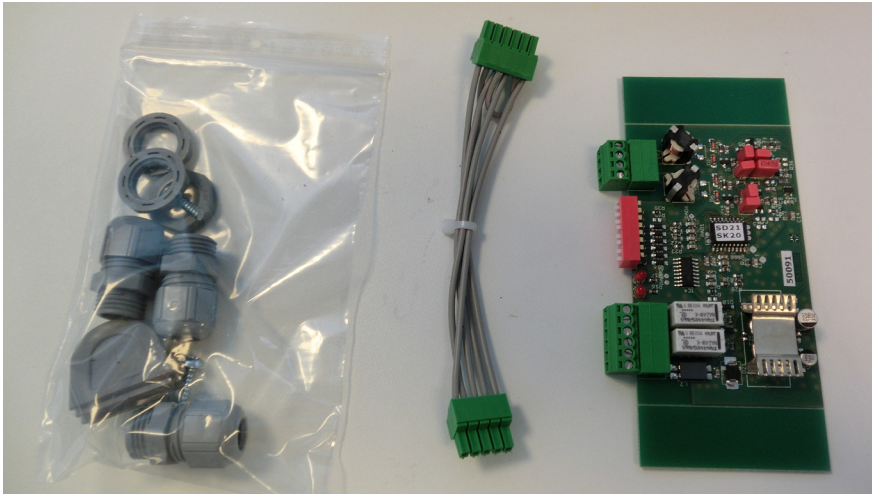

This is a double detector to connect 2 loops. The connection is at terminal KL23 in the ForceIQ.
The detailed adjustments are described in the supplied manual and the wiring is shown in the electrical drawing.
No need to adjust settings in the menu of the ForceIQ.

Terminal	Function
1 / 2	Loop 1
3 / 4	Loop 2

Terminal	Function
1 / 2	Switching output 1
3 / 4	Switching output 2
5	+ 24V DC
6	GND

Setting DIP-switches:

DIP=switch	Function
1	Frequency adjustment
2	Frequency adjustment
3	Sensitivity loop 1
4	Sensitivity loop 1
5	Sensitivity loop 2
6	Sensitivity loop 2
7	Direction detection
8	Frequency boost (truck with buildup)

4.3. ForceRX4: radio receiver

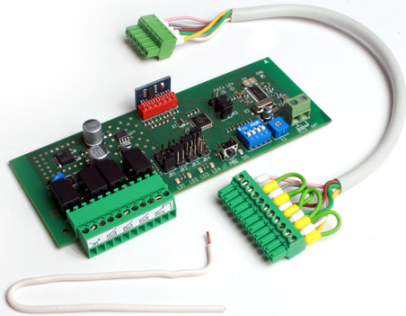

ForceTX4: Hand-held transmitter



This is a 4 channel radio receiver. The connecting is at terminal KL1 in the ForceIQ. The detailed adjustments are Described in the supplied manual and the wiring is shown in the electrical drawing.

No need to adjust settings in the menu of the ForceIQ.

The compatible transmitters are the ForceTX4

Channel 1	Impulse (open.stop/close)
Channel 2	Open
Channel 3	Close
Channel 4	Stop

4.4. forceTL: traffic light

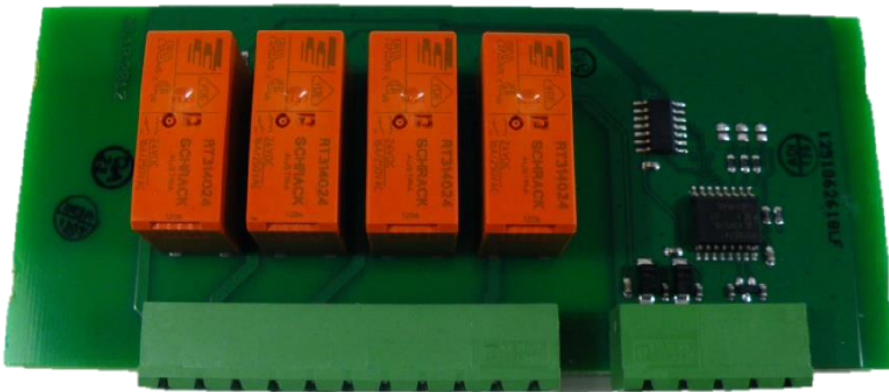

The Traffic light module has 4 integrated relays. The connection is at terminal KL22 in the ForceIQ. The detailed adjustments are described in the supplied manual and the wiring is shown in the electrical drawing. For more info and adjustments see 3.4.7 traffic lights page 20.

4.5. Photocells (for example we use the OS-IR)



With the forceIQ two kits are possible

Connect the photocells as below

OS-IR	ForceIQ KL4	ForceIQ KL5
Brown (transmitter)	4	1
Brown (receiver)	3	1
Blue (both)	1	4
yellow	2	3
black	1	1

See also basic wiring diagram

Photocell 1, terminal KL5:

- Use the ← or → arrow to navigate to the "Safety devices" menu. Press ✓ to enter the menu.
- Use the ← or → arrow to select "4-wire photocell disabled". Press ✓ to enter the menu.
- Use the ← or → arrow to select "Untested". Press ✓ to confirm.
- Use the ← or → arrow to navigate to "Down full reverse". Press ✓ to confirm.
- Press the ↑ arrow twice to enter the maneuvering mode

Photocell 2, terminal KL4:

- Use the ← or → arrow to navigate to the "Safety devices" menu. Press ✓ to enter the menu.
- Use the ← or → arrow to select "OSE 2 setup KL4". Press ✓ to enter the menu
- Use the ← or → arrow to select "4-W photoc. KL4 ". Press ✓ to confirm.
- Use the ← or → arrow to navigate to "Down full reverse". Press ✓ .
- Press the ↑ arrow twice to enter the maneuvering mode.

Switch off photocell 1 function at installed position of the optics:

This function will enable you to switch the photocell ON or OFF.

- Use the ← or → arrow to navigate to the "Safety devices" menu. Press ✓ to enter the menu.
- Use the ← or → arrow to select "4-wire photocell disabled". Press ✓ to enter the menu.
- Use the ← or → arrow to select "Untested". Press ✓ to confirm.
- Use the ← or → arrow to navigate to "Down full / sw off". Press to confirm.
- Use ⌚ or ⌚ to adjust to the desired position were the photocell has to switch off.
- Press 2x ✓ to confirm
- Press 2x ↑ to return to the maneuvering mode.



It is not possible to switch off photocell 2 at the installed position of the optics

4.6: forceOSE

Connect:

Connect the 3pole connector of the forceOSE Optosensor kit to KL3 in the control unit.
If you use a slack rope switch, you can connect the 2pole connector to KL7.
If you use a pass door switch, you can connect the 2pole connector to KL2 1-2 or KL2 3-4.
Make sure a 8.2 kΩ is connected if you use KL2 (See also basic wiring diagram)

Settings optosensor

- Use the ← or → buttons to navigate to the "Safety device" menu.
- Press ✓ to enter the menu.
- Use the ← or → buttons to select "OSE1 KL3". Press ✓ to confirm.
- Use the ← or → buttons to select "OSE". Press ✓ to confirm.
- Use the ← or → buttons to select "down full rev.". Press ✓ to confirm
- Press ↑ to return to the main menu.
- Press ↑ once more to enter the manoeuvring mode.

Settings for the pass door switch:

- Use the ← or → buttons to navigate to the "Safety device" menu.
- Press ✓ to enter the menu.
- Use the ← or → buttons to select "Safety 1" for KL2 1-2 and "Safety 2" for KL2 3-4. Press ✓ to confirm.
- Use the ← or → buttons to select "passdoor".
- Press ✓ to confirm and save.
- Press ↑ to return to the main menu.
- Press ↑ once more to enter the maneuvering mode.



You don't have to adjust the slack rope switch, this is recognized by the control unit.

4.7 forcePSE

Connect:

Connect the 4Pole connector of the Force PSE to KL2.(green and white on 1-2)
Make sure a 8.2 kΩ is connected if you use KL2 (See also basic wiring diagram)
If you use a slack rope switch, you can connect the 2pole connector to KL8.
If you use a pass door switch, you can connect the 2pole connector to KL2 3-4

Settings for the PSE:

- Use the ← or → buttons to navigate to the "Safety device" menu.
- Press ✓ to enter the menu.
- Use the ← or → buttons to select "Safety1". Press ✓ to confirm.
- Use the ← or → buttons to select "Airwave switch". Press ✓ to confirm.
- Use the ← or → buttons to select "down full rev."
- Press ✓ to confirm and save.
- Press ↑ to return to the main menu.
- Press ↑ once more to enter the maneuvering mode.

settings for the pass door switch:

- Use the ← or → buttons to navigate to the "Safety device" menu.
- Press ✓ to enter the menu.
- Use the ← or → buttons to select "Safety 2". Press ✓ to confirm.
- Use the ← or → buttons to select "passdoor".
- Press ✓ to confirm and save.
- Press ↑ to return to the main menu.
- Press ↑ once more to enter the maneuvering mode.



You don't have to adjust the slack rope switch, this is recognized by the control unit.

4.8 force668LM, electronic lock.



For this lock you need an additional power supply.
If the lock works the wrong way round, then swap KL14 and KL15

Connecting LM668 to Force IQ control box

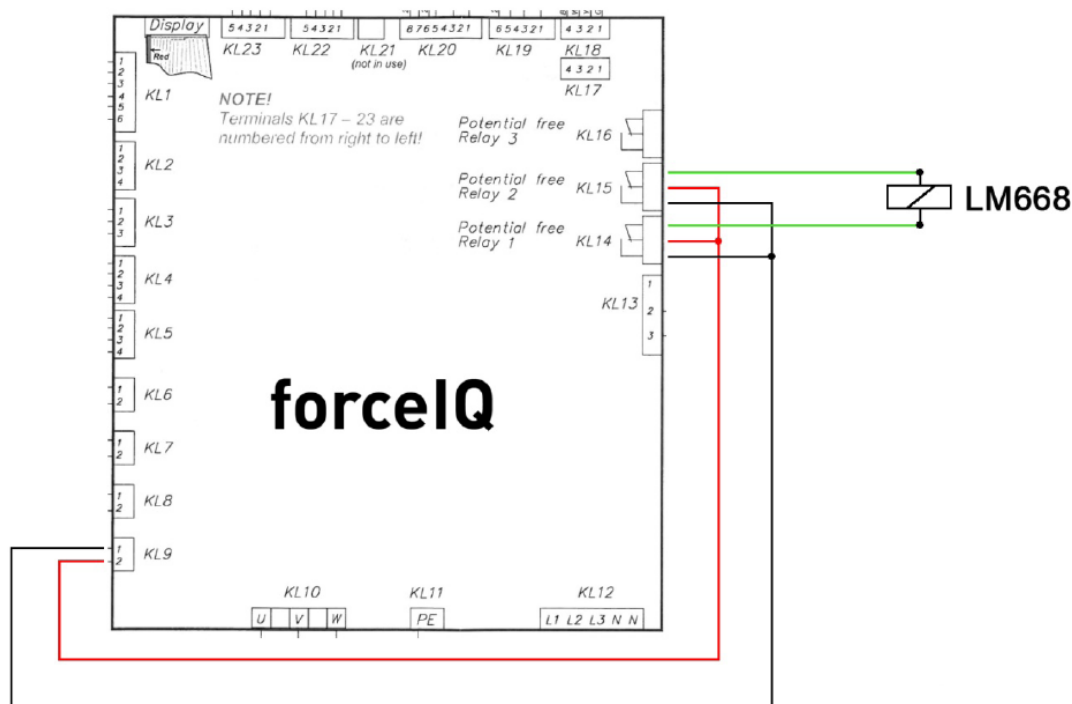

- Use the ◀ or ▶ buttons to navigate to the "Special setup" menu. Press ✓ to enter the menu.
- Use the ◀ or ▶ buttons to select "Relays". Press ✓ to confirm.
- Use the ◀ or ▶ buttons to select "Relay 1". Press ✓ to confirm.
- Use the ◀ or ▶ buttons to select "R1 TYPE EL.LOCK". Press ✓ to confirm.
- Use the ◀ or ▶ buttons to select "Lock open". Press ✓ to confirm.
- Set prerun time on 1 second. Press ✓ to confirm and save.
- Use the ◀ or ▶ buttons to navigate to the "Relay 2" menu. Press ✓ to enter the menu.
- Use the ◀ or ▶ buttons to select "R2 TYPE EL.LOCK". Press ✓ to confirm.
- Use the ◀ or ▶ buttons to select "MODE LOCK CLOSE". Press ✓ to confirm and save.
- Press ⬆ to return to the main menu.
- Press ⬆ once more to enter the maneuvering mode.

5. Trouble shooting

5.1 Event message

Event message	Reason
OSE 1 ERROR	Safety device on OSE 1 port is defect KL3
OSE 2 ERROR	Safety device on OSE 2 port is defect KL4
SAFE.EDGE 1 ERR.	Safety device on SR1 port is defect KL2:1-2
SAFE.EDGE 2 ERR.	Safety device on SR2 port is defect KL2:3-4
4W-PHOTO. ERROR	Safety device on 4wire port is defect
DOOR SAFETY	Safety chain triggered, open circuit KL 7
MOTOR SAFETY	Safety chain triggered, open circuit KL 8
BLOCKED POSITIONER	Encoder communication error or no encoder KL18
INVERTER ERROR	Inverter communications error
BATTERY EMPTY	Dalmatic encoder reports its batteries are empty
OUT OF RANGE	Door moved past the end positions
UNAUTHORIS. MOVE	Door moved when it was not supposed to
DOOR TOO SLOW	Door did not move even though it should have
DOOR TOO FAST	Door was moving too fast (door speed monitoring)
WRONG DIRECTION	Door was moving in the wrong direction
ERROR BAD CONFIG	The stored configuration was missing/invalid
FACTORY RESET	Factory reset has been issued from the menu
ENDPOS. CHANGED	The end positions have been changed in menu
SEC.DEV. CHANGED	Safety device setting has been changed
REVERSED 3 TIMES	The door has reverse X times in a row and auto close has been disabled as a result
MEMORY FAULT RAM	Error has been detected during the RAM self test
MEM. FAULT FLASH	The flash CRC calculation has detected an error
MEM.FAULT EEPROM	The EEPROM CRC calculation has detected an error
SYSTEM POWER UP	System has been reset and is now starting up
PASSDOOR OPEN	Pass door has been opened while the door was moving
OSE 1 TRIGGERD	Safety device connected to KL 3 is activated
OSE 2 TRIGGERD	Safety device connected to KL4 is activated
SAFE. EDGE 1 TRIGGERD	Safety device connected to KL2 1-2 is activated
SAFE. EDGE 2 TRIGGERD	Safety device connected to KL2 1-2 is activated
4W-PHOTO. TRIGGERD	Safety device connected to KL5 is activated

5.2 trouble shooting

Problem	Solution
Error code won't disappear from display even if safety edge are OK.	Clear history file in service settings
"Blocked positioner"	Adjust limit switch type/ check encoder connection
"Blocked out of range / stutter mode"	Use safety chain/crank or hand to move the door in right position.
Operator is not moving, but you can hear the contact switch clicking	- Check Fuses F1,F2 and F3 -Check incoming Power (230V between N en L)
Not possible to adjust end positions	- Could happen after using the quick release. Lock the door in position by moving it a little by hand. - Check encoder settings
display without text	Check connection cable between cover and controlbox. The red stripe on the flatcable has to be on the left side.
Quick release won't work	Make sure there is tension on the cables and the springs. Bottom adjustment can be to tight on the floor.
Safety edge won't work	If you have mechanical limit switch, make sure you have connected KL19 pin 5 and 6. You can connect them together. Plug power back on.
Can't shut of Force IR	Make sure that If you use an optosensor both transmitters are on the same side of the door.
ForceLC2 react spontaneously	Make sure the door covers up all the led's
Operator won't go up/down only buzzing noise	230V operator:Check if wire W from KL10 is connected to the blue wire in the motor. 400V operator: check the 3 phases and the fuses.
Forgot the password	Contact your supplier.

Appendix

6. 1 Additional function-terminals

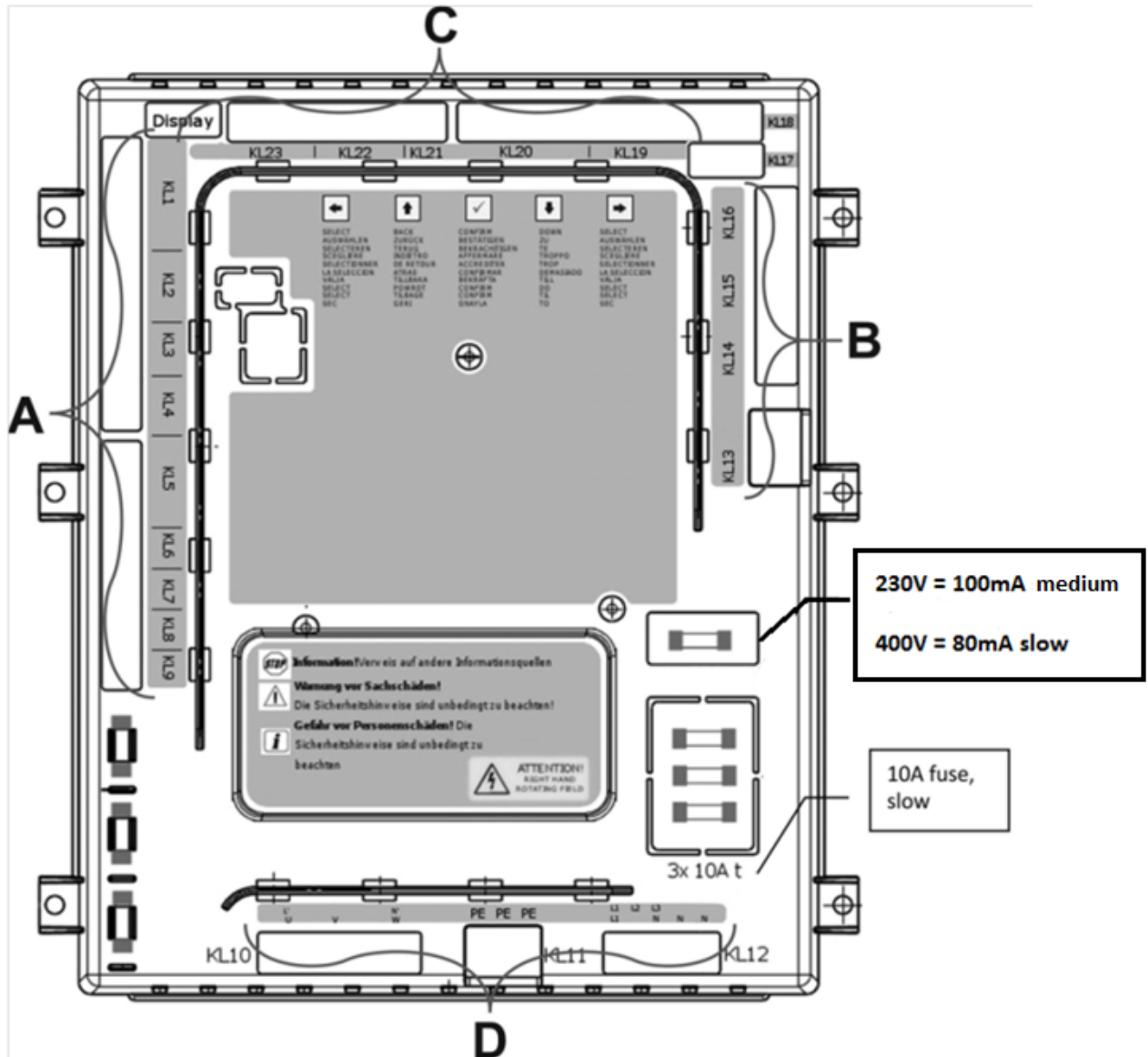

- | | |
|---------------------------------------|---|
| KL1 = radio modul | KL14 = potential free contacts Rel.1 |
| KL2 = 8,2 kOhm safety edge | KL15 = potential free contacts Rel.2 |
| KL3 = OSE 1 | KL16 = potential free contacts Rel.3 |
| KL4 = OSE 2 | KL17 = RS485-2 (optional) |
| KL5 = light curtain, 4-wire photocell | KL18 = RS485-1 |
| KL6 = 2-wire photocell | KL19 = connector mech. limit switches |
| KL7 = safety circuit 1 | KL20 = connector external commands |
| KL8 = safety circuit 2 | KL21 = thermo-contact motor |
| KL9 = 24V connector | KL22 = connector traffic module |
| KL10= motor connector | KL23 = connector induction loop module backside |
| KL11= PE-earth connector | KL24 = power supply 24V input |
| KL12= connector main supply | KL25 = power supply 230 VAC |
| KL13 = change over 400/230V | KL26 = PE earth connector |

Terminal group A:

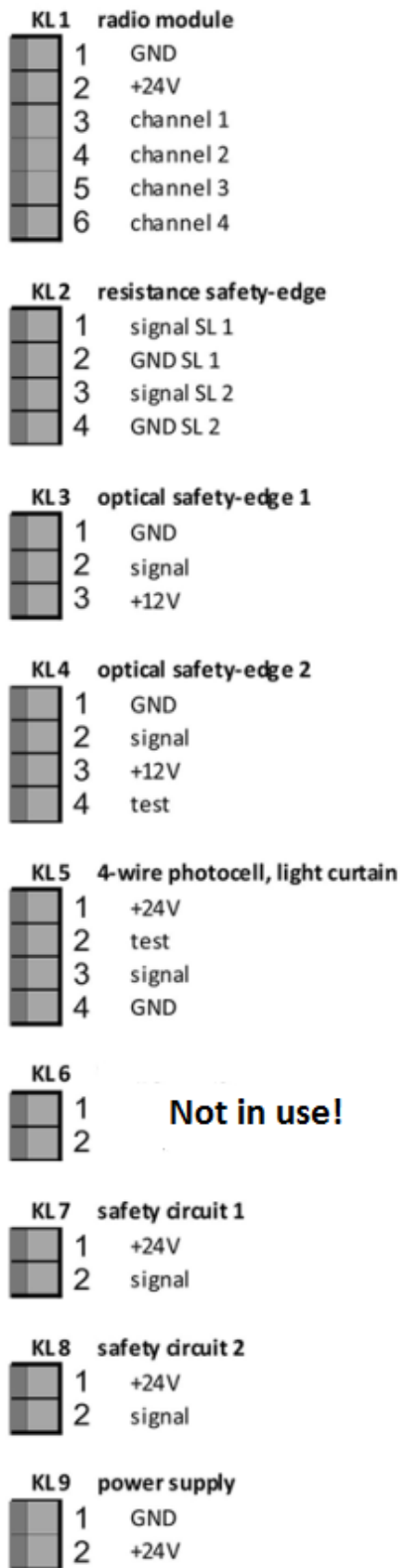

Terminal group B:

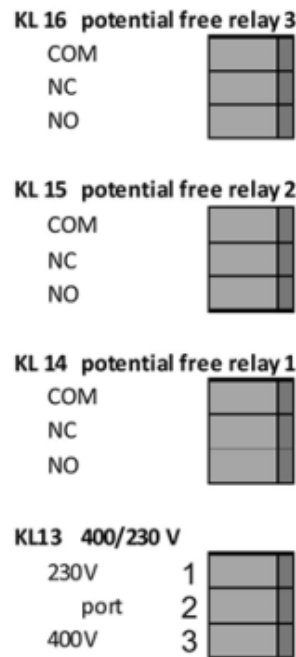

Terminal group C:

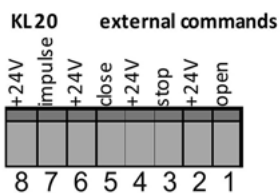
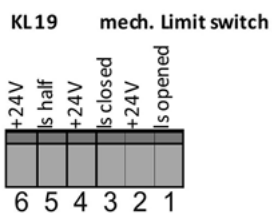
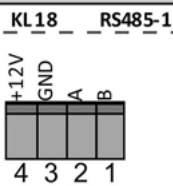
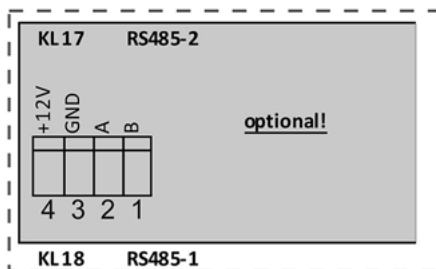
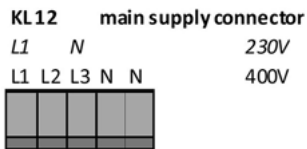
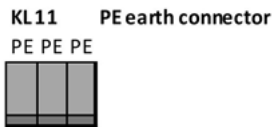
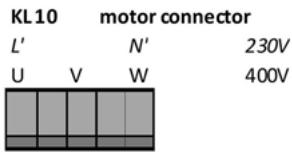

Terminal group D:

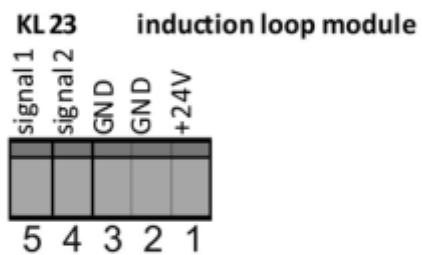
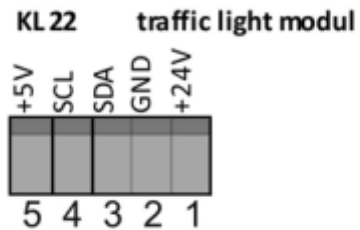
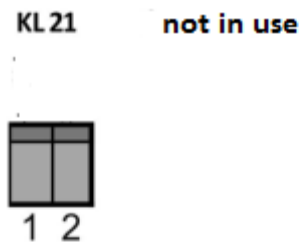

Backside connectors

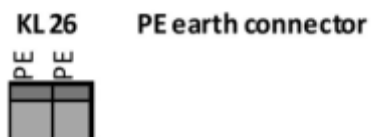
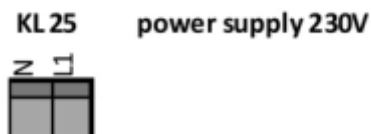
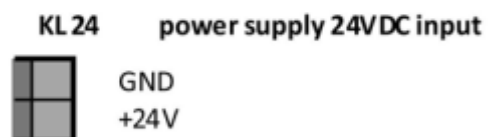

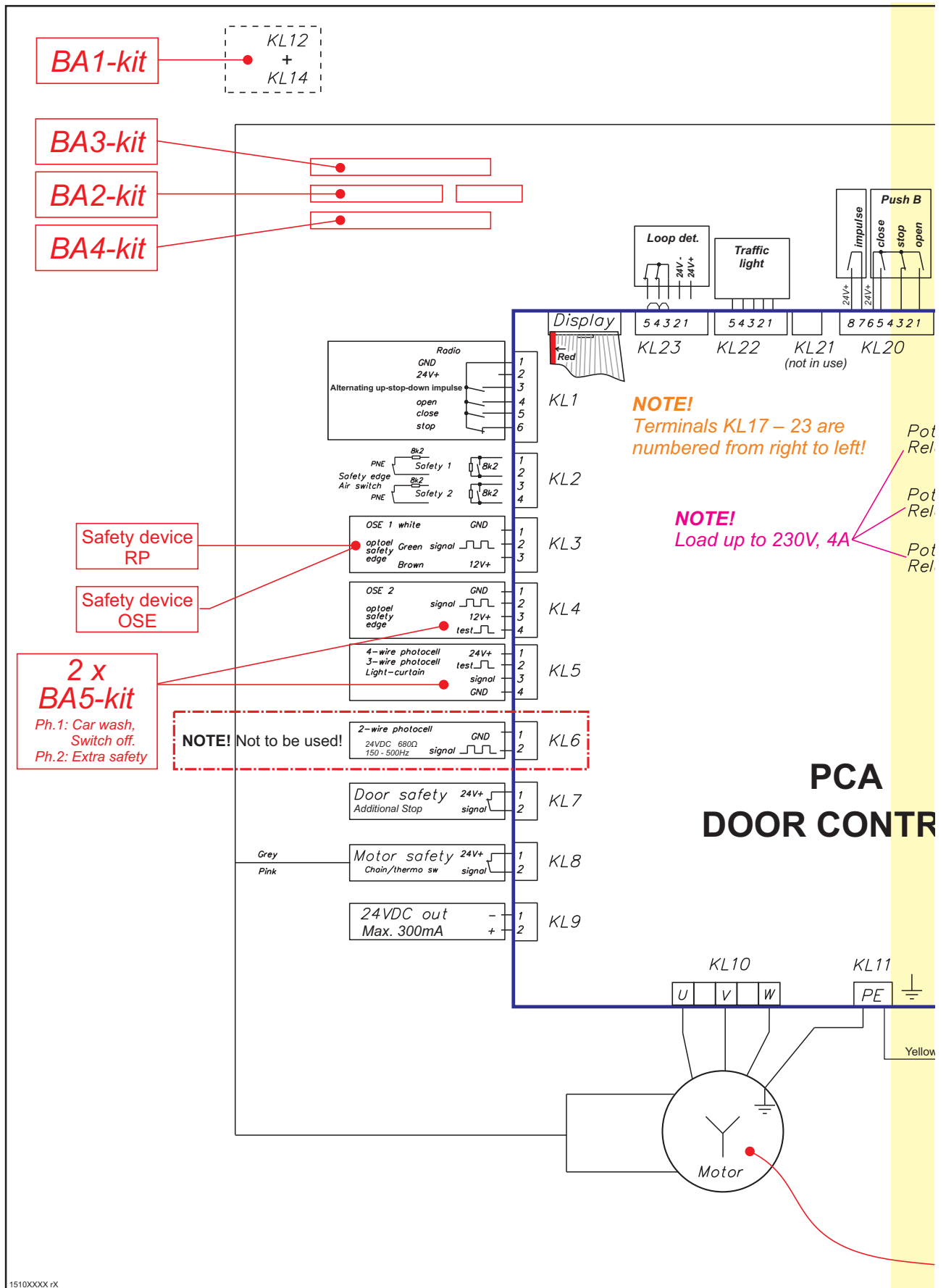

1510XXXX rX

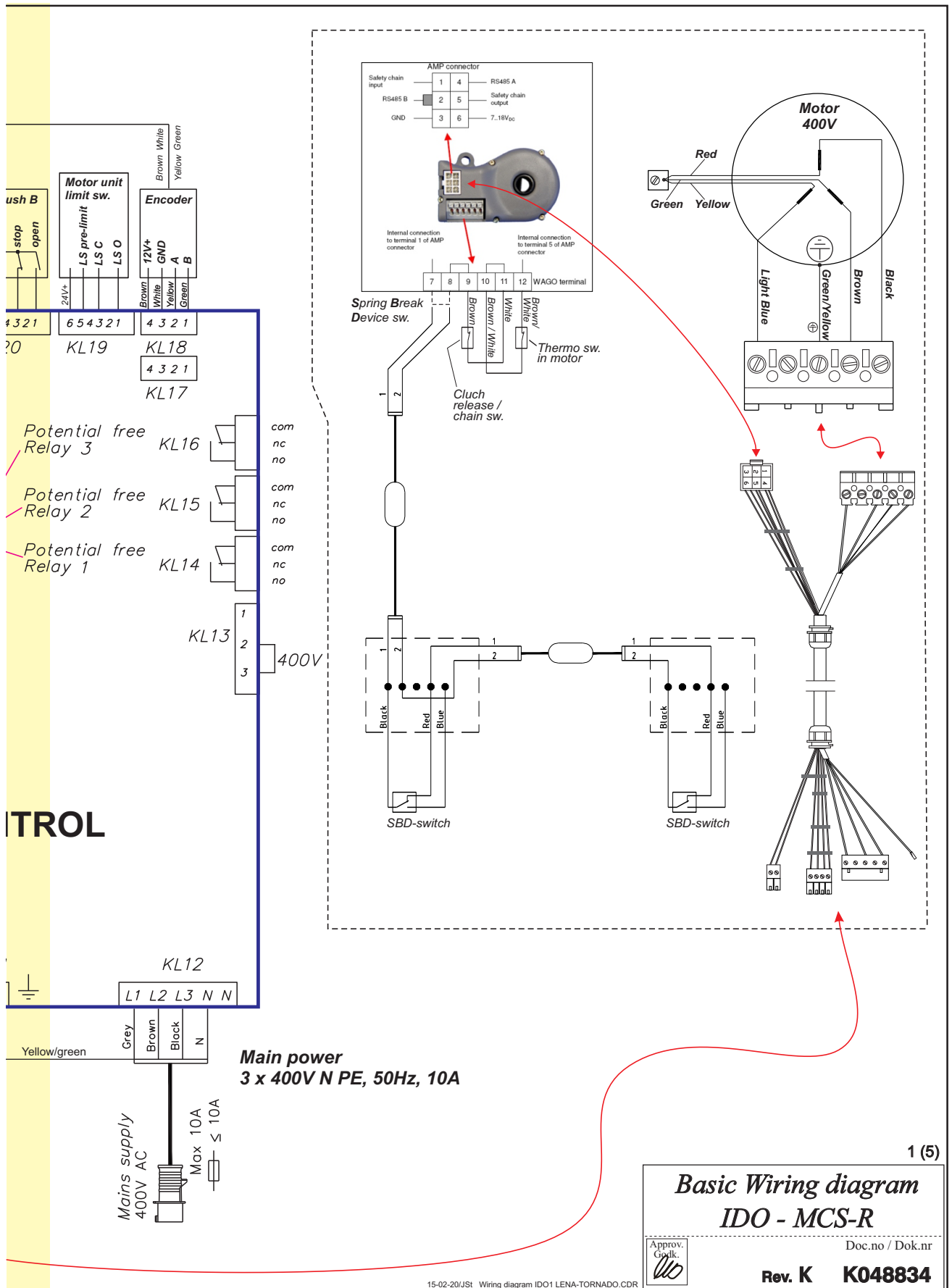

1 (5)

Basic Wiring diagram
IDO - MCS-R

Approv. Doc.no / Dok.nr

Rev. K K048834

15-02-20/JSI Wiring diagram IDO1 LENA-TORNADO.CDR

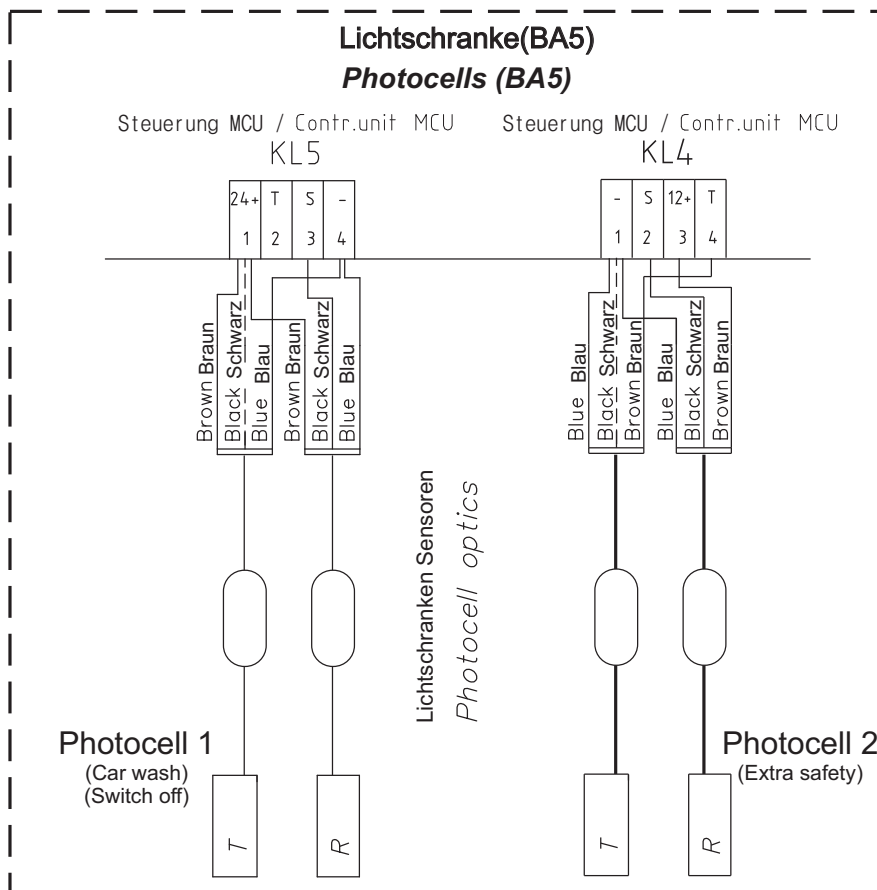
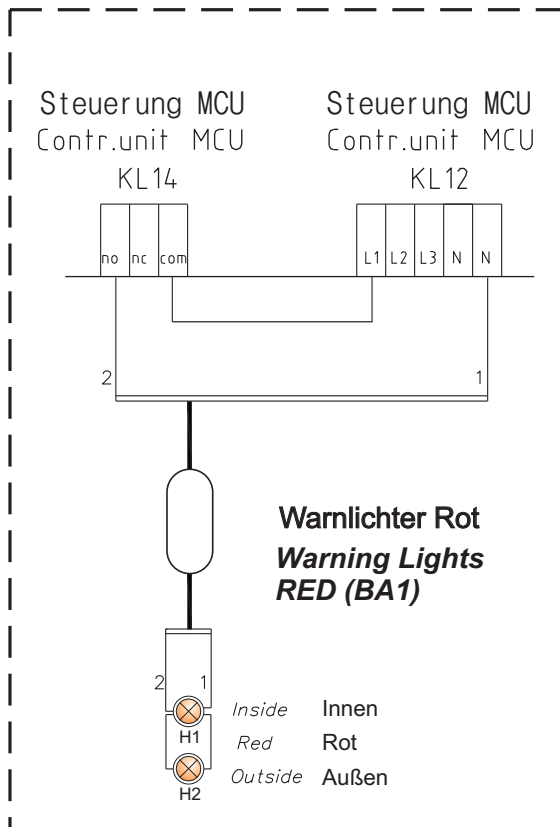

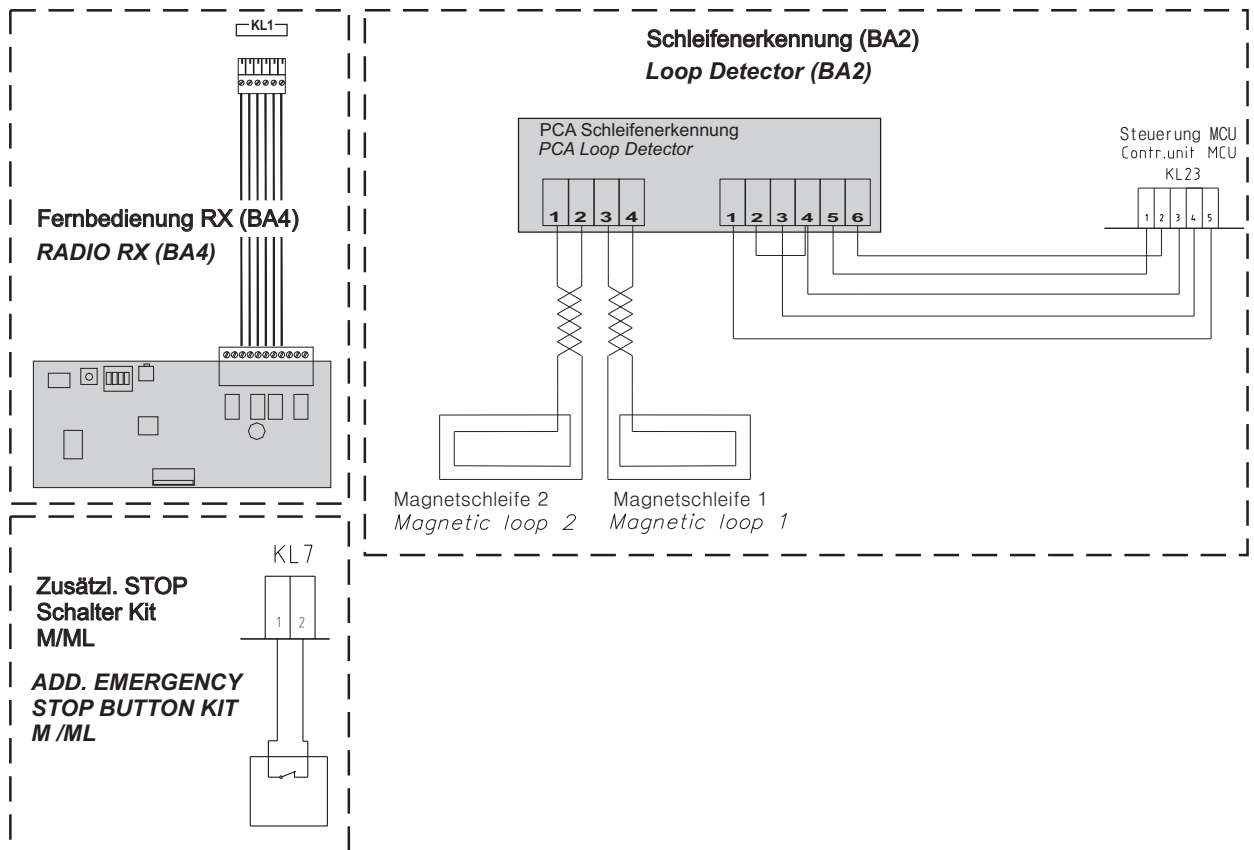
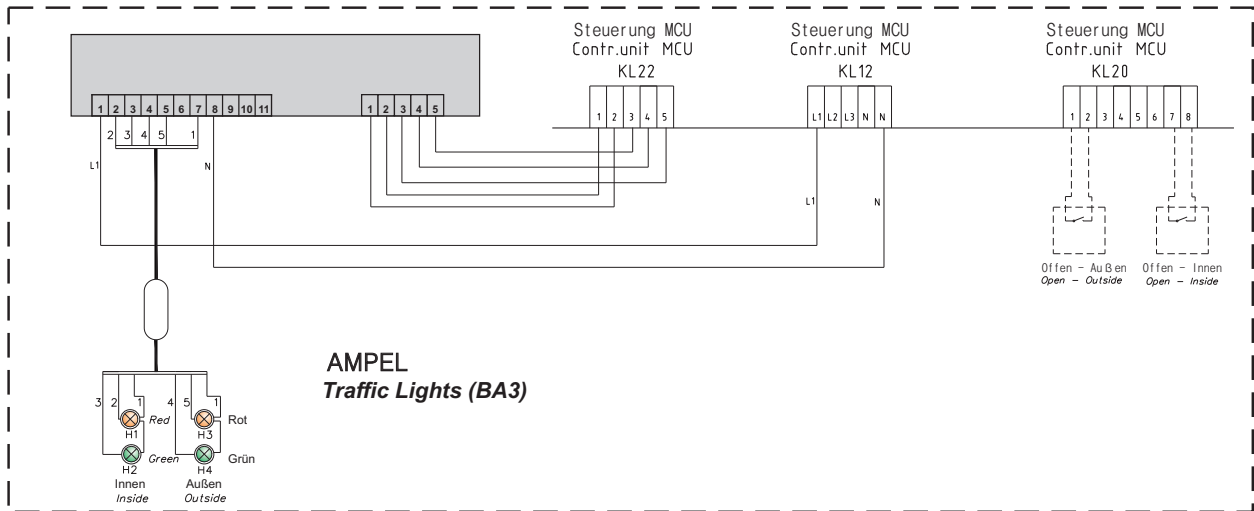

Declaration of Incorporation

We:

Flexi-Force Group BV
Hanzeweg 25
3771 NG Barneveld
The Netherlands

declare under our sole responsibility that the type of equipment :

Industrial sectional overhead door drives force70XQ, force100XC, force100XQ, force140XQ and control units forceIQ and forceIQ-230 with radio remote control, are in compliance with the following directives:

- 2004/108/EC** **Electro Magnetic Compatibility Directive (EMCD)**
2002/95/EC **Restriction of the use of Hazardous Substances in electrical and electronic equipment (RoHS)**
1999/5/EC **Radio and Telecommunications Terminal Equipment Directive (R&TTE)**
2006/42/EC **Machinery Directive (MD) the following essential health and safety requirements:**
1.1.2, 1.1.3, 1.2.1, 1.2.2, 1.2.3, 1.2.4, 1.2.5, 1.2.6, 1.3.1, 1.3.2, 1.3.4, 1.3.7, 1.3.8, 1.3.9, 1.4.2, 1.5.1, 1.5.2, 1.5.4, 1.5.5, 1.5.6, 1.5.7, 1.5.10, 1.5.11, 1.5.12, 1.5.13, 1.5.16, 1.6.3, 1.6.4, 1.7.3, 1.7.4.
Technical documentation for safe integration is provided

Harmonized European standards which have been applied:

EN 13849-1 EN 61000-6-1 EN 61000-6-2 EN 61000-6-3 EN 61000-6-4 EN 12453 EN 60335-1

Other standards or technical specifications, which have been applied:

EN 60335-2-103

The manufacturing process ensures the compliance of the equipment with the technical file.

A door operator, in combination with an automatic door system must be installed and maintained according to all manufacturer's instructions, to meet the provisions of EN12453 and EN13241-1. The equipment must not be used until the final installed door system has been declared in compliance with the machine directive 2006/42/EC by the installation company.

Compilation of technical file:

Ton Peterse

Flexi-Force Group BV
Hanzeweg 25
3771 NG Barneveld
The Netherlands

Place Date
Barneveld 18-09-2015

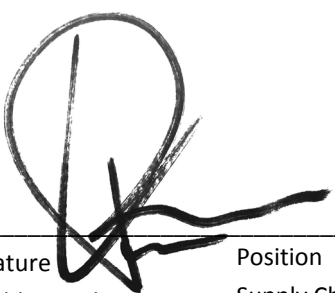

Signature Position
Ronald Koenders Supply Chain Director.